

## High Productivity Cooking Electric Pressure Braising Pan, 110lt with Backsplash, CTS & Tap

ITEM # \_\_\_\_\_

MODEL # \_\_\_\_\_

NAME # \_\_\_\_\_

SIS # \_\_\_\_\_

AIA # \_\_\_\_\_

**586811 (PUEN11KPEM)**

Electric Pressure Braising Pan 110lt (s) with steam condensation function, core temperature sensor and mixing tap, GuideYou panel, backsplash

### Short Form Specification

#### Item No.

AISI 304 stainless steel construction. Pan in AISI 304 stainless steel; 18mm thick pan bottom (15mm mild steel and 3 mm AISI 316 stainless steel). Insulated and counterbalanced lid. Water mixing unit included. Unit to include food tap. The electric heating elements are mounted under the well. Safety thermostat protects the pan from overheating. A precise, electronic control of pan bottom temperature ensures fast reaction and exact adherence to preselected cooking temperatures between 50° and 250°C. The steam condensation function automatically nullifies the steam pressure after cooking is completed at the end of the cooking cycle. It can be used for poaching or steaming (with the lid open); simmering and boiling (with open or closed lid); pressure cooking of multiple produces possible thanks to the use of suspended GN 1/1 containers. TOUCH control panel. SOFT function. PRESSURE function. Possibility to store recipes in single or multiphase cooking process, with different temperature settings. Built in temperature sensors for precise control of cooking process. Core Temperature Sensor provides efficient temperature control. IPX6 water resistant. Configuration: Standing against a wall. Installation options (not included): floor mounted on 100mm high feet or a plinth which can be either steel or masonry construction.

### Main Features

- Multifunctional cooking appliance used for roasting, pot-roasting, braising, simmering, boiling, pressure cooking and steaming.
- Square inner kettle allows working with stacked Gastronorm containers, which facilitate loading and unloading operations.
- Thermoblock heating system for optimal temperature distribution and high temperature stability.
- Pan bottom with two individually adjustable heating zones, each with a temperature sensor.
- Large capacity food tap enables safe and effortless discharging of contents.
- Easy to clean cooking surface due to large-radius edges and corners.
- Temperature sensors provides efficient temperature control: the power is supplied as and when required to keep the set temperature value without exceeding it.
- Optimum heat distribution in the food provides best cooking results in terms of taste, colour and consistency and in terms of vitamin preserving.
- Discharge tap is very easy to disassemble and clean.
- Safety mechanism prevents lid from opening, even in case of voluntary attempt, when cooking under pressure.
- "Pressure function": once the pressure lid is locked, the system automatically regulates itself.
- Built in temperature sensor to precisely control the cooking process.
- Core Temperature Sensor (CTS): multi-sensor food probe, 6 sensors, 0,5 °C accuracy, provides efficient temperature control. The power is supplied as and when required to keep the set temperature value without exceeding it and once reached, the food is ready to be served.
- USB connection to easily update the software, upload/download recipes and download HACCP data.
- Cooking with a working pressure of 0.45 bar reduces cooking times.
- Overnight cooking: saving electricity and time.
- Safety valve on the lid avoids overpressure in the food compartment.
- IPX6 water resistant.
- No overshooting of cooking temperatures, fast reaction.

### Construction

- Multipurpose non-stick cooking surface in 18

APPROVAL: \_\_\_\_\_

### boiling

- Pressure mode (in pressure models)
- Stirrer ON/OFF settings (in round boiling models)
- Error codes for quick trouble-shooting
- Maintenance reminders

### User Interface & Data Management

- Connectivity ready for real time access to connected appliances from remote and data monitoring (requires optional accessory - contact the Company for more details).

### Sustainability



- High-quality thermal insulation of the pan saves energy and keeps operating ambient temperature low.

### Optional Accessories

- |   |            |                          |
|---|------------|--------------------------|
| • Strainer for dumplings for all tilting & stationary braising and pressure braising pans (except 80lt) and for all stationary rectangular and 100lt round boiling pans | PNC 910053 | <input type="checkbox"/> |
| • Scraper for dumpling strainer for boiling and braising pans   | PNC 910058 | <input type="checkbox"/> |
| • Suspension frame GN1/1 for rectangular boiling and braising pans  | PNC 910191 | <input type="checkbox"/> |
| • Base plate 1/1 GN for braising pans   | PNC 910201 | <input type="checkbox"/> |
| • Perforated container with handles 1/1GN (height=100mm) for boiling and braising pans  | PNC 910211 | <input type="checkbox"/> |
| • Perforated container with handles 1/1GN (height 150mm) for boiling and braising pans  | PNC 910212 | <input type="checkbox"/> |
| • Small perforated shovel for braising pans (PFEN/PUEN)   | PNC 911577 | <input type="checkbox"/> |
| • Small shovel for braising pans (PFEN/PUEN)  | PNC 911578 | <input type="checkbox"/> |
| • Scraper with horizontal handle for braising pans (PFEN/PUEN)  | PNC 911579 | <input type="checkbox"/> |
| • Perforated container with handles 1/1GN (height 200mm) for boiling and braising pans  | PNC 911673 | <input type="checkbox"/> |
| • Power Socket, CEE16, built-in, 16A/400V, IP67, red-white - factory fitted   | PNC 912468 | <input type="checkbox"/> |
| • Power Socket, CEE32, built-in, 32A/400V, IP67, red-white - factory fitted   | PNC 912469 | <input type="checkbox"/> |
| • Power Socket, SCHUKO, built-in, 16A/230V, IP68, blue-white - factory fitted   | PNC 912470 | <input type="checkbox"/> |
| • Power Socket, TYP23, built-in, 16A/230V, IP55, black - factory fitted   | PNC 912471 | <input type="checkbox"/> |
| • Power Socket, TYP25, built-in, 16A/400V, IP55, black - factory fitted   | PNC 912472 | <input type="checkbox"/> |
| • Power Socket, SCHUKO, built-in, 16A/230V, IP55, black - factory fitted  | PNC 912473 | <input type="checkbox"/> |
| • Power Socket, CEE16, built-in, 16A/230V, IP67, blue-white - factory fitted  | PNC 912474 | <input type="checkbox"/> |
| • Power Socket, TYP23, built-in, 16A/230V, IP54, blue - factory fitted  | PNC 912475 | <input type="checkbox"/> |
| • Power Socket, SCHUKO, built-in, 16A/230V, IP54, blue - factory fitted   | PNC 912476 | <input type="checkbox"/> |
| • Power Socket, TYP25, built-in, 16A/400V, IP54, red-white - factory fitted   | PNC 912477 | <input type="checkbox"/> |
| • Drain standpipe for 110/170lt stationary braising pans and stationary pressure braising pans  | PNC 912478 | <input type="checkbox"/> |
| • Measuring rod and strainer for 110lt stationary braising pans   | PNC 912484 | <input type="checkbox"/> |

- Manometer for stationary pressure braising pans and rectangular pressure stationary boiling pans - factory fitted PNC 912492
- Connecting rail kit for appliances with backsplash, 900mm PNC 912499
- Set of 4 feet for stationary units (height 100mm) - factory fitted PNC 912701
- Automatic water filling (hot and cold) for stationary units (width 700-1000mm): rectangular pressure boiling and braising pans - factory fitted PNC 912736
- Kit energy optimization and potential free contact - factory fitted PNC 912737
- Mainswitch 25A, 4mm<sup>2</sup> - factory fitted PNC 912773
- External touch control device for stationary units - factory fitted PNC 912783
- Emergency stop button - factory fitted PNC 912784
- Wall mounting kit for stationary units - factory fitted PNC 912787
- Connecting rail kit for appliances with backsplash: modular 90 (on the left) to ProThermetic tilting (on the right), ProThermetic stationary (on the left) to ProThermetic tilting (on the right) PNC 912981
- Connecting rail kit for appliances with backsplash: modular 90 (on the right) to ProThermetic tilting (on the left), ProThermetic stationary (on the right) to ProThermetic tilting (on the left) PNC 912982
- Rear closing kit for stationary units with backsplash - factory fitted PNC 912997
- Stainless steel plinth for stationary units - against the wall - factory fitted PNC 913303
- Kit endrail and side panels, flush-fitting, for installation with backsplash, left - factory fitted PNC 913388
- Kit endrail and side panels, flush-fitting, for installation with backsplash, right - factory fitted PNC 913389
- Kit endrail and side panel (12.5mm), for installation with backsplash, left - factory fitted PNC 913412
- Kit endrail and side panel (12.5mm), for installation with backsplash, right - factory fitted PNC 913413
- Scraper without handle for braising pans (PFEX/PUEX) PNC 913431
- Scraper with vertical handle for braising pans (PFEX/PUEX) PNC 913432
- Connectivity kit for ProThermetic Boiling and Braising Pans ECAP - factory fitted PNC 913577

### Recommended Detergents

- C41 HI-TEMP RAPID DEGREASER, 1 pack of six 1 lt. bottles (trigger incl.) PNC 0S2292

# High Productivity Cooking Electric Pressure Braising Pan, 110lt with Backsplash, CTS & Tap

Front

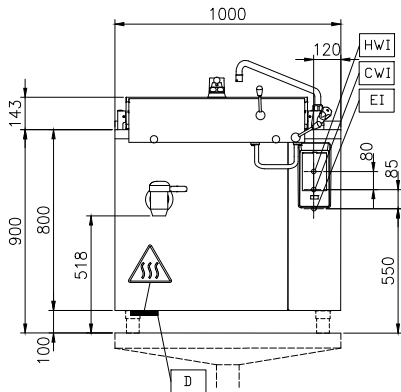

Side

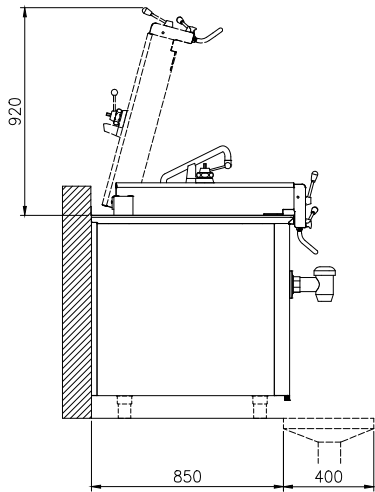

CWI = Cold Water inlet 1 (cleaning)  
 EI = Electrical inlet (power)  
 HWI = Hot water inlet

Top

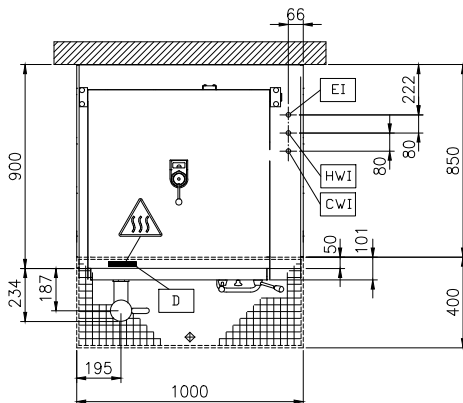

## Electric

Supply voltage: 400 V/3N ph/50/60 Hz  
 Total Watts: 15.5 kW

## Installation:

### Type of installation:

FS on concrete base; FS on feet; On base; Standing against wall; Wall mounted (with wall-kit)

## Key Information:

Working Temperature MIN: 50 °C  
 Working Temperature MAX: 250 °C  
 Vessel (rectangle) width: 680 mm  
 Vessel (rectangle) height: 340 mm  
 Vessel (rectangle) depth: 550 mm  
 External dimensions, Width: 1000 mm  
 External dimensions, Depth: 900 mm  
 External dimensions, Height: 800 mm  
 Net weight: 200 kg

### Configuration:

Net vessel useful capacity: 110 lt  
 Double jacketed lid: ✓  
 Heating type: Direct

Rectangular; Fixed; With splashback

Direct